

A. S. GEAR.
Machines for Turning Stone.

No. 136,432.

Patented March 4, 1873.

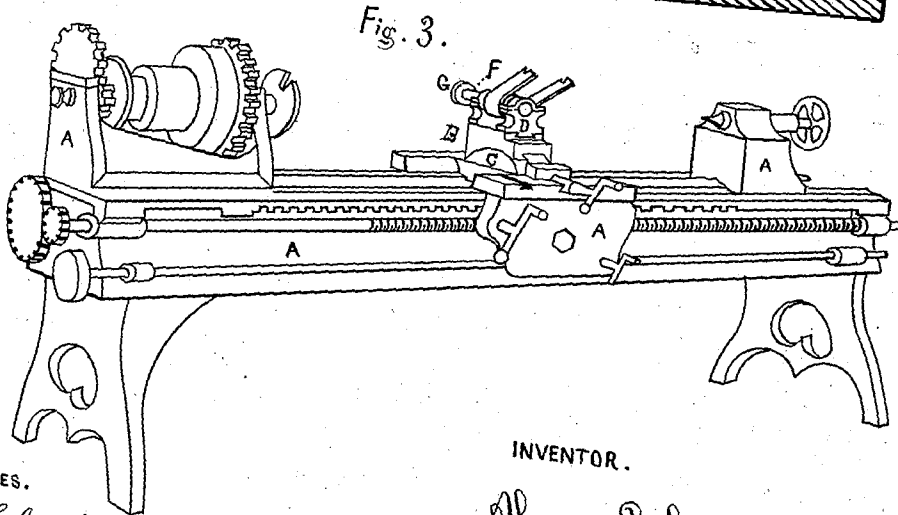
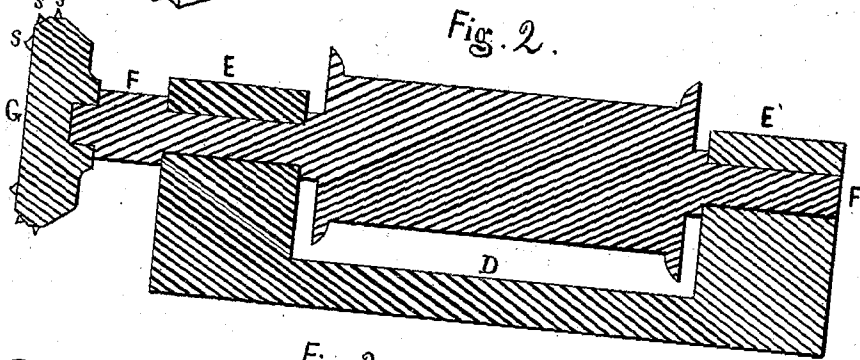
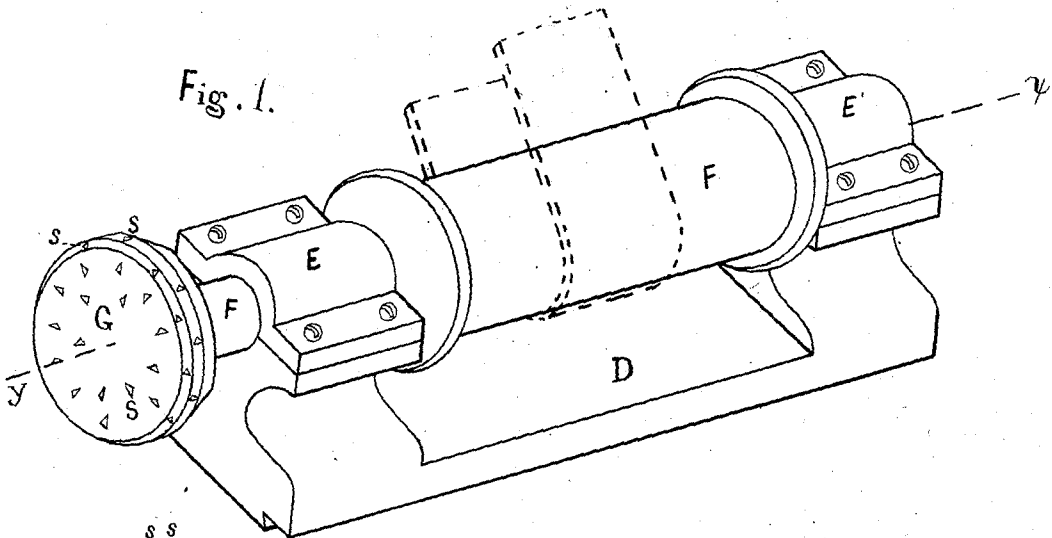

WITNESSES.
Geo Clark
George C. Carter

INVENTOR.
Alonso S. Gear
per Sylvanus Walker
Atty

UNITED STATES PATENT OFFICE.

ALONZO S. GEAR, OF BOSTON, MASSACHUSETTS.

IMPROVEMENT IN MACHINES FOR TURNING STONE.

Specification forming part of Letters Patent No. 136,432, dated March 4, 1873.

To all whom it may concern:

Be it known that I, ALONZO S. GEAR, of Boston, in the county of Suffolk and State of Massachusetts, have invented certain Improvements in Stone-Turning Machines, of which the following is a specification:

My invention relates to a rotary cutter-head studded with diamonds for turning stone; and it consists in the combination of such rotary cutter-head with the common well-known engine-lathe, said cutter-head being connected to such engine-lathe in the place of the turning-tool now used, by means of suitable journal-boxes attached to a plate or bed-piece which is confined to the tool-stock in such manner as to admit of being moved laterally, and to permit a slight elevation or depression of the cutter-head, which is made to revolve at a very high rate of speed by means of a one-fourth twist-belt which passes around a flanged pulley upon a longitudinal arbor or shaft carrying such rotary cutter-head, whose cutting-face stands nearly in a vertical position, and connects with a drum overhead running at right angles with such cutter-head shaft, and being in line with the stone to be turned so as to allow said belt to traverse said drum as the cutter-head is carried along the lathe by a screw-shaft connected to the cutter-stock in the usual manner for such purpose.

A pillar or column of stone to be turned is placed in the lathe in the same manner that a piece of iron would be if it was to be turned, and motion imparted to it by the lathe in the usual manner; then the swift-revolving rotary cutter-head, studded with diamonds, is brought in contact with the slow-revolving stone; the diamonds upon the periphery of such cutter-head cut away the highest projecting portions of the same by partially cutting in under the same when the rear bevel or rotary wedge upon the cutter-head comes in contact beneath such projections and chips or breaks them off; then the diamonds upon the face of the cutter-head further reduce the

stone until it is turned to the size and shape desired; thus I am enabled to turn a pillar or column of stone or other article desired with the same facility that iron is turned at the present time in the common engine-lathe.

Figure 1 is a perspective view of the rotary cutter-head studded with diamonds as detached from the engine-lathe. Fig. 2 is a vertical central section of the same, as indicated by dotted lines *x y*, Fig. 1. Fig. 3 is a perspective view of the engine-lathe with rotary cutter-head as attached for use.

A A represents the common engine-lathe of the usual construction, except the cutter-stock B, which is provided with means of attaching the base-plate D to its top, the bottom being attached to the semicircular base C, or in any other preferred way, so as to admit of the elevation and depression of the cutter-head G. D is the base-plate containing the journal-boxes E E' in which the arbor F of the cutter-head G revolves; the periphery and outer portion of the face of the cutter-head G are studded with diamonds S S S, as shown in Fig. 1. This rotary cutter-head may be constructed of steel entire, or the rear portion may be of chilled cast-iron, and of any form desired, and from an inch to an inch and a half in diameter, more or less, as desired, being constructed suitable to run at a very high rate of speed.

I have omitted to describe the engine-lathe with which my invention is combined; it being old and well-known I do not claim its invention, it being a distinct and separate machine of itself used for other purposes; but

What I claim as my invention, and desire to secure by Letters Patent, is—

In combination with an engine-lathe, a rotary cutter-head, studded with diamonds, for turning stone, substantially in the manner described, as and for the purposes set forth.

ALONZO S. GEAR.

Witnesses:

SYLVENUS WALKER,
L. W. BRADLEY.